



**HARDY LEAN
SOLUTIONS**

MODULAR DUMPING SYSTEM

TIPPER™

USER ASSEMBLY INSTRUCTIONS

SYSTEM OVERVIEW

One machine — configurable in four sizes to meet your needs.

Designed to dump a variety of containers

- Trash cans
- Gondola carts up to 1.5 cubic yards
- Pallets
- Gaylord containers

Specifications

- Capacity — 1000 lbs
- 24V hydraulic pump
- Dual 80AH AGM batteries
- Onboard 120 VAC, 20A smart charger
- Optional solar charging system
- 6 inch locking casters for easy movement
- Locking feet

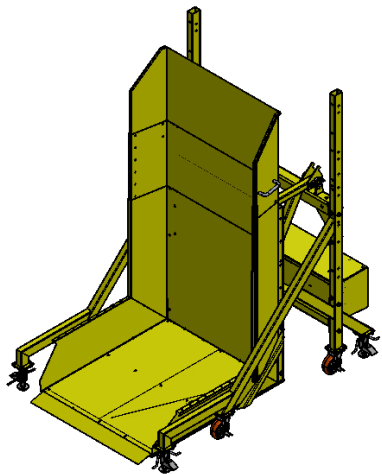

**63 Inch
Dump Over Configuration**

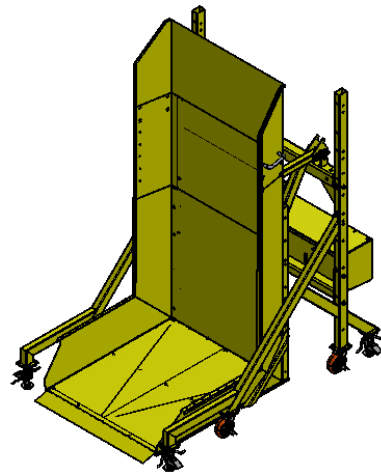

**72 Inch
Dump Over Configuration**

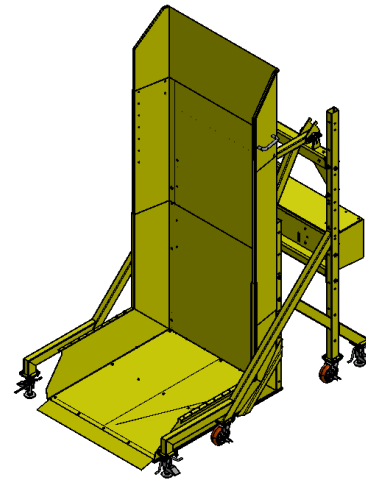

**84 Inch
Dump Over Configuration**

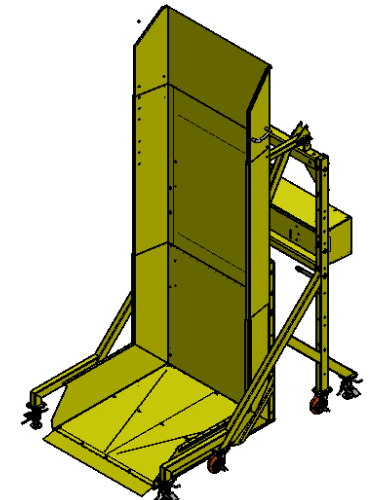

**100 Inch
Dump Over Configuration**

63 INCH DUMP OVER CONFIGURATION

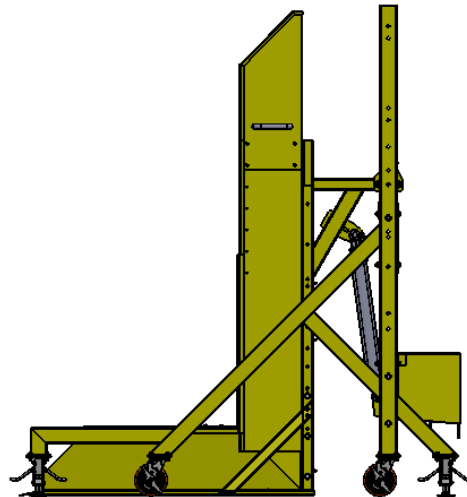
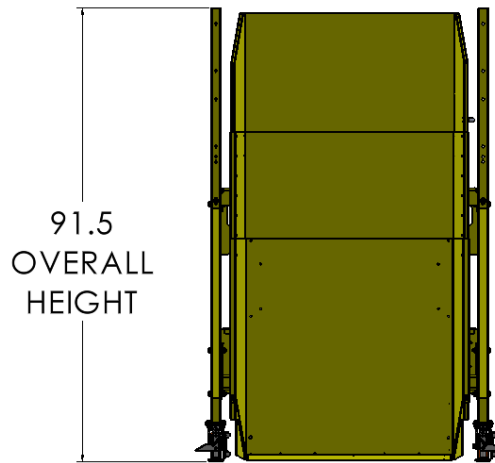
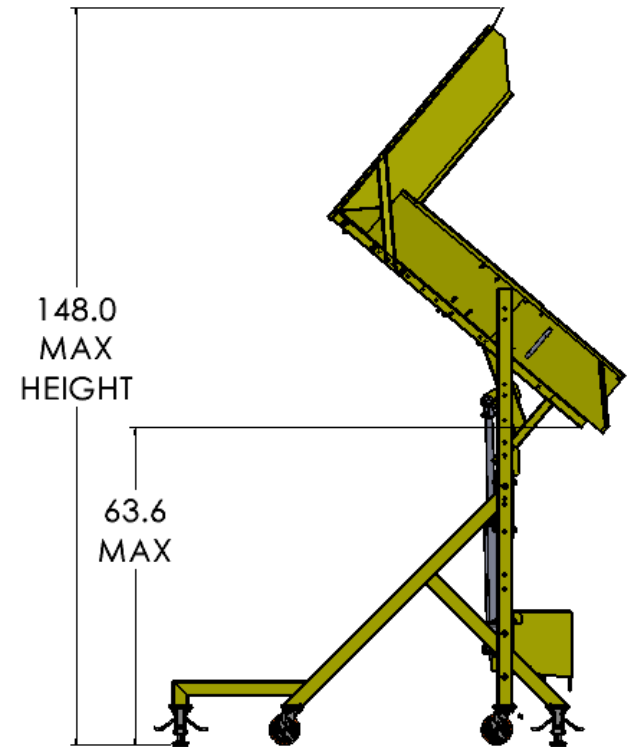
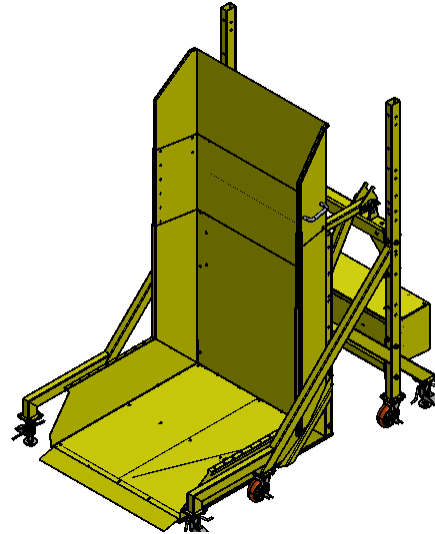
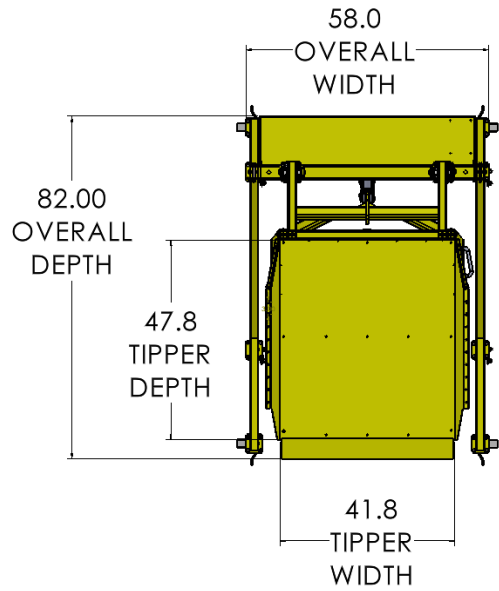

72 INCH DUMP OVER CONFIGURATION

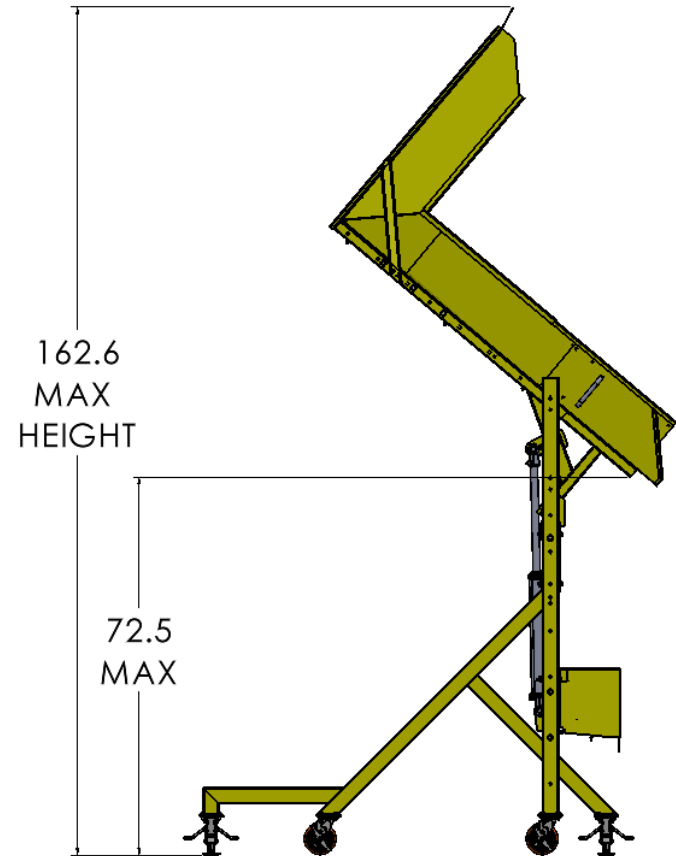
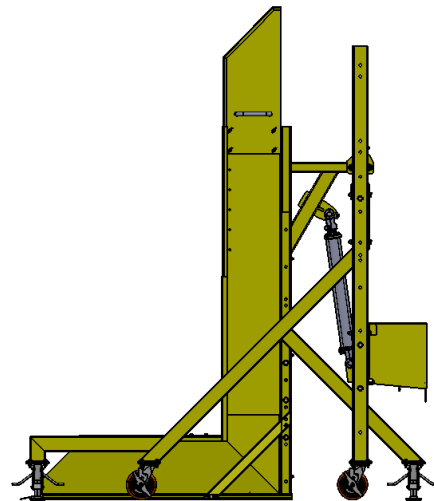
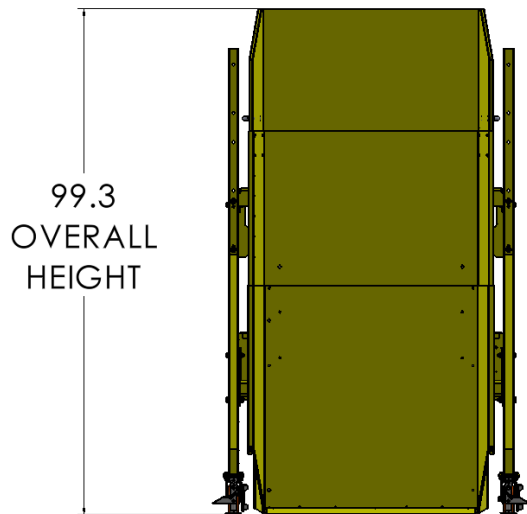
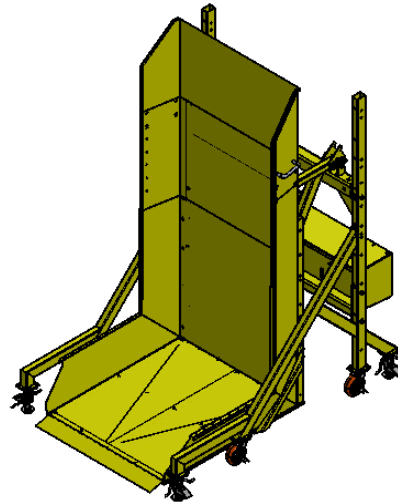
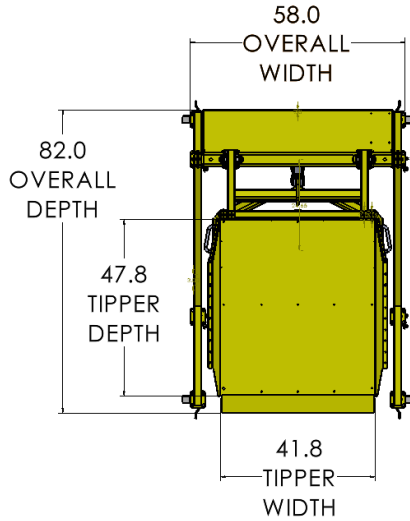

84 INCH DUMP OVER CONFIGURATION

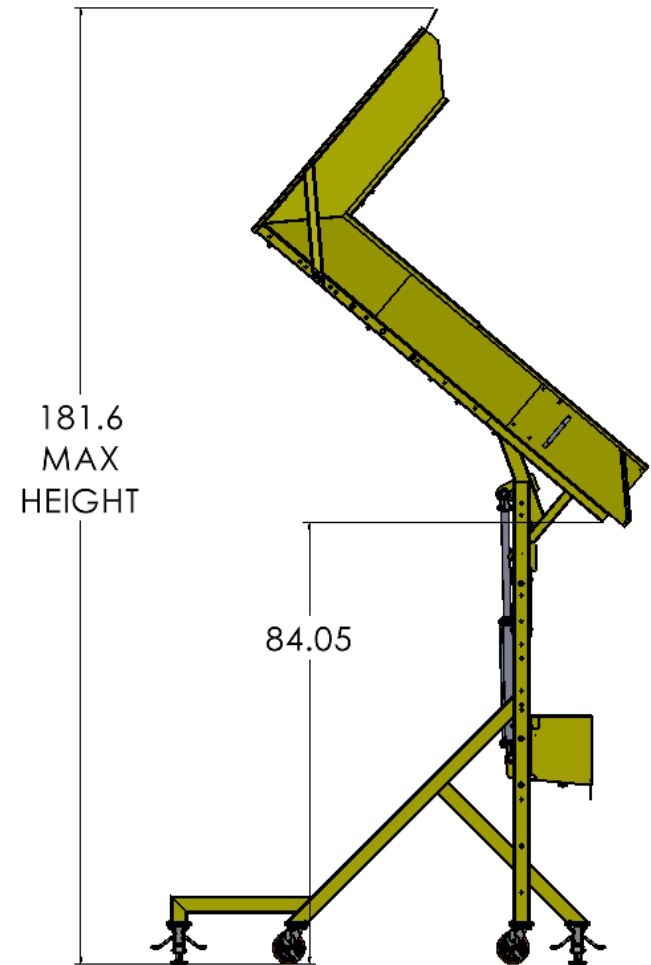
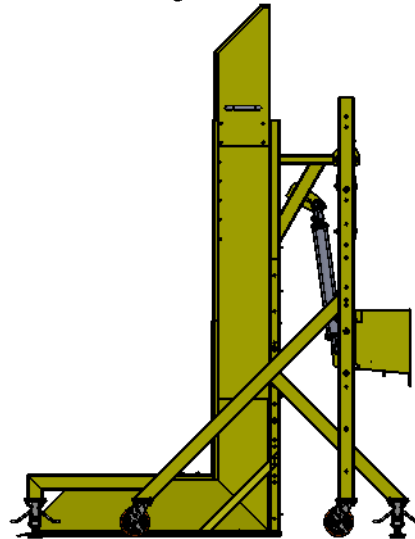
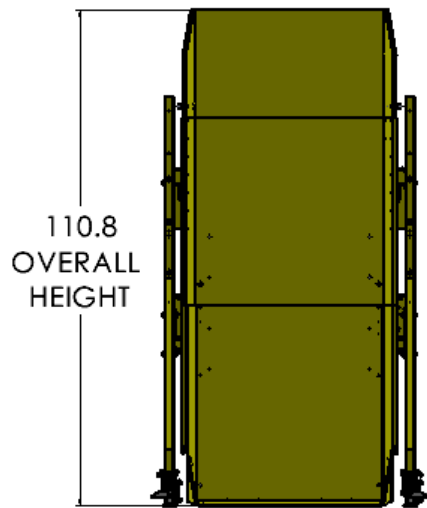
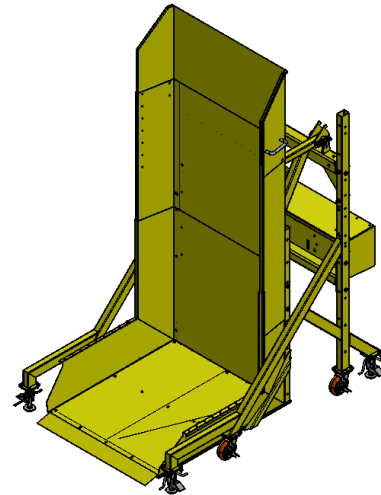
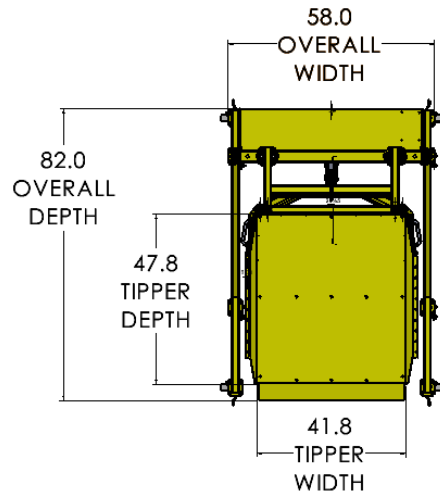

100 INCH DUMP OVER CONFIGURATION

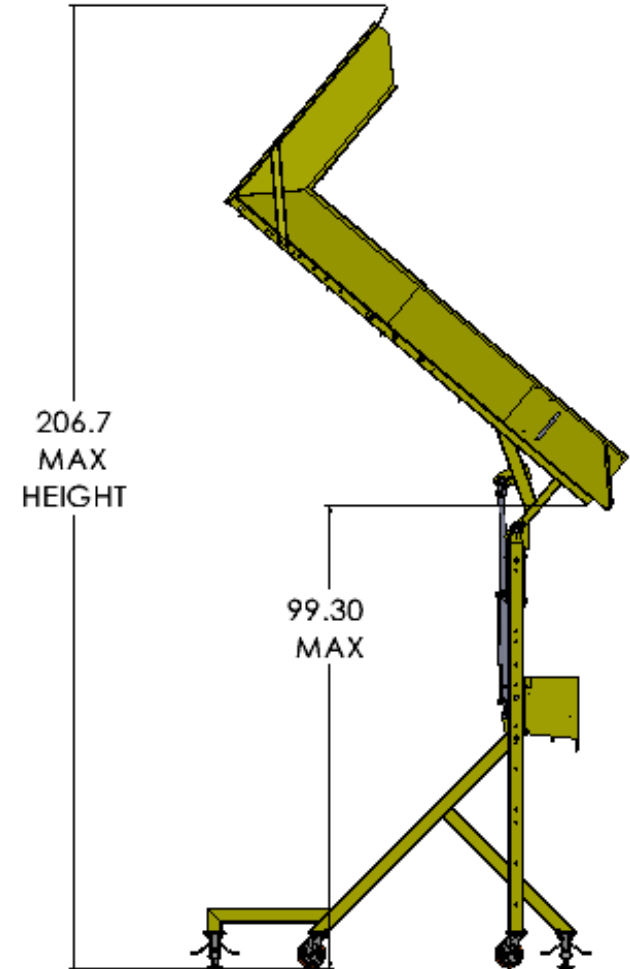
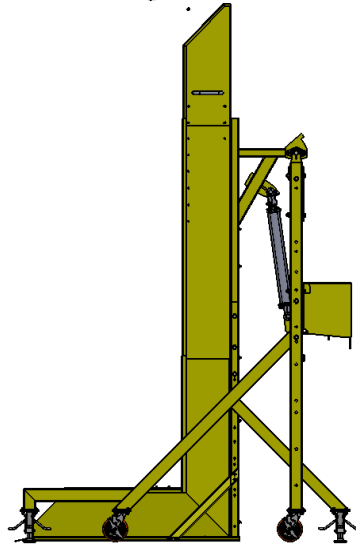
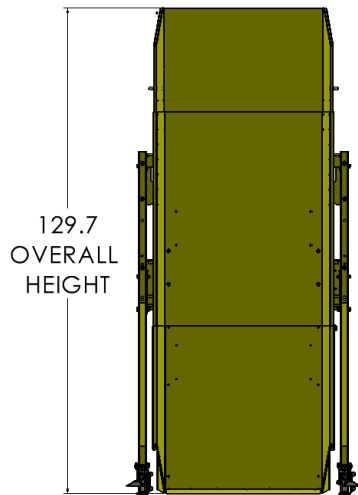
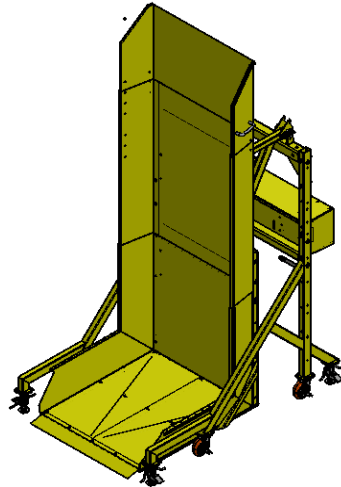
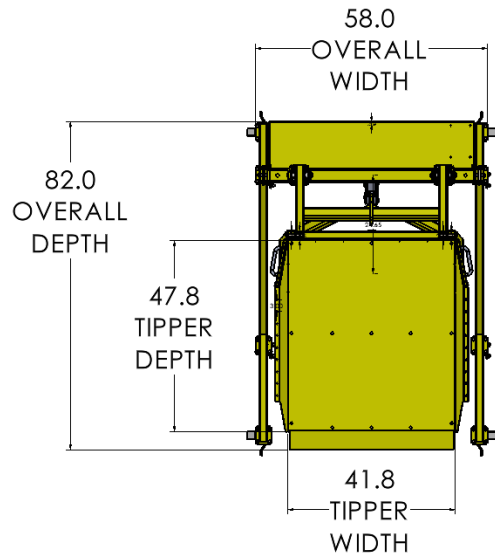

CHUTE EXTENSION

Adjust chute extension to 6 positions

- 24 inch total adjustable range
- 4 inch increments
- Able to be completely removed
- Adjustment without the need for tools through the use of common wingnuts
- Extra wingnuts and holes provided for stability in most extended position

